



Ersatzteilliste

Spare parts list

Liste de pièces de rechange

ProfiLine FS/FZ (IB+)
Modelle 36-20 bis 48-42

Wechselrahmen

Change frames

Cadres porte-outils

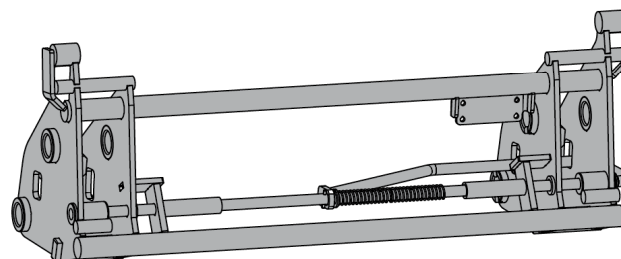
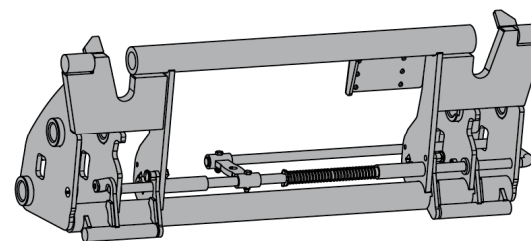
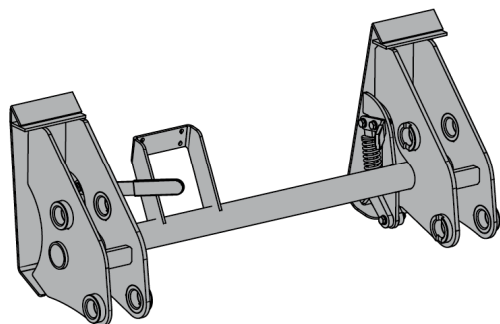

3755980

Gültig für Maschinen Nr. / Valid for serial No. / Valable pour No:
ab/from/dés 7250666

E58WR4

2025

Bei Ersatzteilbestellungen sind die Seriennummer Ihrer Maschine und, wenn möglich, das Baujahr unbedingt anzugeben. Das erspart Ihnen Zeit, Geld und Ärger und erleichtert uns die Abfertigung. Tragen Sie die Nummer Ihrer Maschine bitte hier ein:

Nr: _____ Geliefert am _____

Dann haben Sie bei Ersatzteilbestellungen die Nummer immer zur Hand. Die Seriennummer ist auf dem Typenschild eingetragen (siehe Abb. 1).

Always state the serial number and if possible the year of the machine when ordering spare parts whereby you save time and money and facilitate matters for us. Please enter the number of your machine here:

Nr: _____ Delivered on the _____

Appropriate when ordering parts. The serial number is located as shown on Fig. 1.

Lorsque vous commandez des pièces de rechange, indiquez toujours le numéro de série de votre machine et si possible son année de fabrication. Vous éviterez des pertes de temps et vous nous faciliterez le travail. Veuillez noter ici le numéro de série de votre machine :

Numéro : _____ Livré le _____

Ceci vous sera utile lorsque vous commanderez des pièces. Le numéro de série est indiqué sur la plaque signalétique (voir Fig. 1).



Abb. 1 / Fig. 1 Typenschild / Rating plate / Plaque signalétique

- 1 Seriennummer / Serial number / Numéro de série
- 2 Baujahr / Year of manufacture / Année de construction

INHALTSVERZEICHNIS	TABLE OF CONTENTS	TABLE DES MATIERES	FS / FZ
Benennung	Description	Désignation	Seite / Page
Mechanischer Wechselrahmen Euro-SMS	Mechanical change frame Euro-SMS	Cadre porte-outils mécanique Euro-SMS	4
Hydraulischer Wechselrahmen Euro-SMS	Hydraulic change frame Euro-SMS	Cadre porte-outils hydraulique Euro-SMS	6
Mechanischer Wechselrahmen Euro-Alö3	Mechanical change frame Euro-Alö3	Cadre porte-outils mécanique Euro-Alö3	10
Mechanischer Wechselrahmen Skid-Steer	Mechanical change frame Skid-Steer	Cadre porte-outils mécanique Skid-Steer	12
Mechanischer Wechselrahmen Euro-MX	Mechanical change frame Euro-MX	Cadre porte-outils mécanique Euro-MX	14
Hydraulischer Wechselrahmen Euro-MX	Hydraulic change frame Euro-MX	Cadre porte-outils hydraulique Euro-MX	16
Adapter Euro-MX	Adapter Euro-MX	Adaptateur Euro-MX	20

DE Mechanischer Wechselrahmen
Euro-SMS

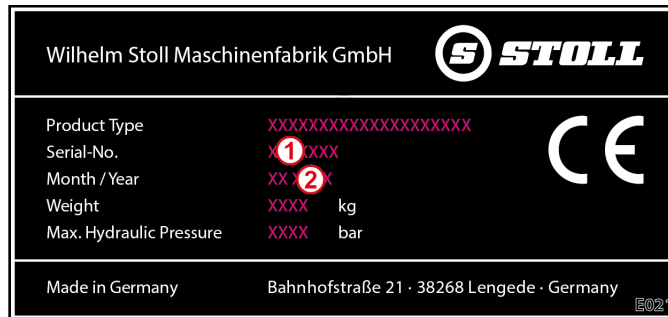
EN Mechanical change frame Euro-
SMS

FR Cadre porte-outils mécanique
Euro-SMS

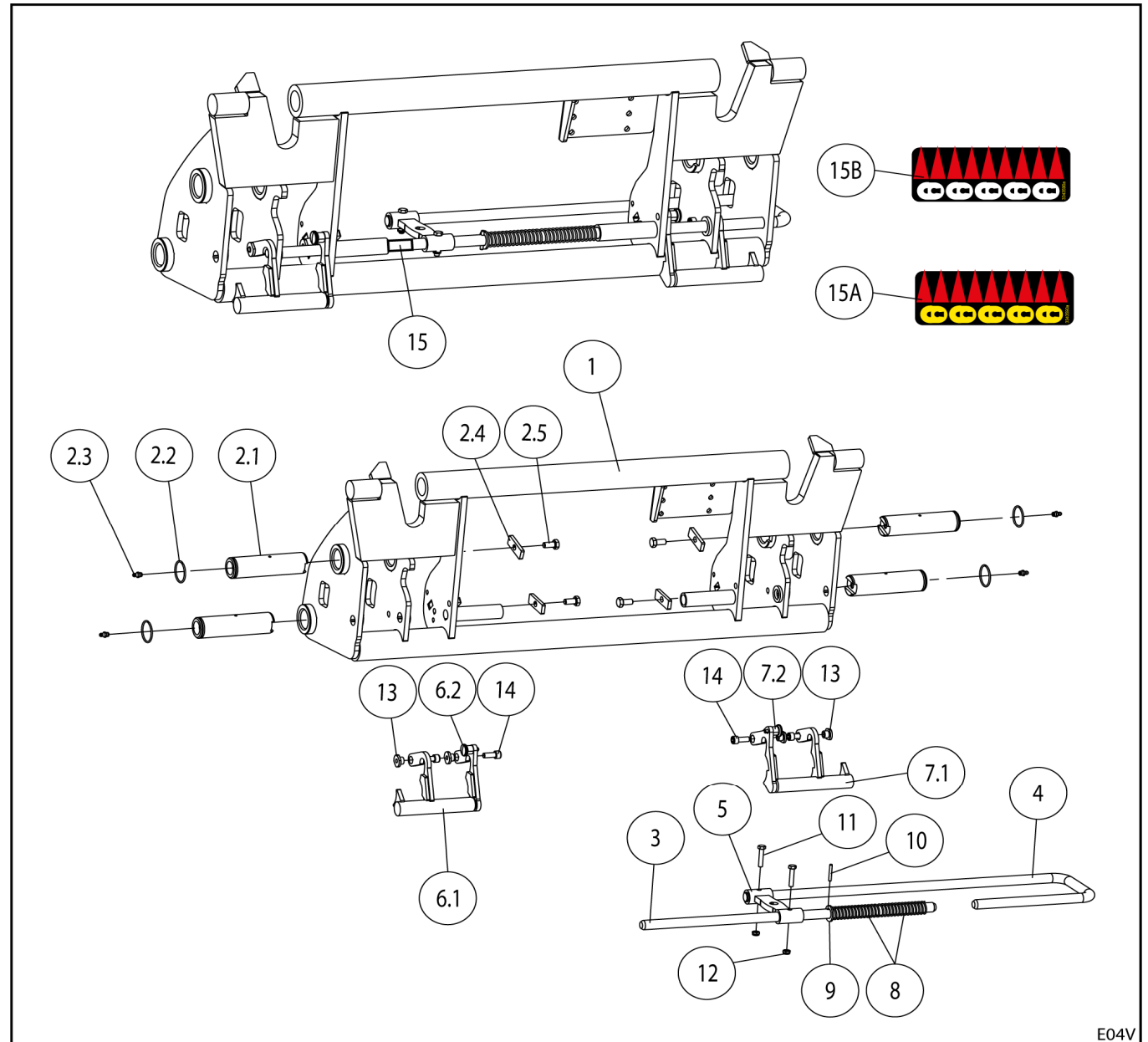

E04V

E04V		Mechanischer Wechselrahmen Euro-SMS	Mechanical change frame Euro-SMS	Cadre porte-outils mécanique Euro-SMS				
Pos.	Bestell-Nr.	Benennung	Description	Désignation	Zeichnungs-Nr.	SIZE/MASS	FS/FZ 36-20 bis 43-34	FS/FZ 36-20.1 bis 48-42.1
1	3729000	Wechselrahmen	Change frame	Cadre porte-outils	58.921-102-04-01		1	--
1	3729060	Wechselrahmen	Change frame	Cadre porte-outils	58.921-103-04-01		--	1
2	3714620	Bolzen kpl.	Bolt cpl.	Boulon complet	58.921-11-02	40x143	4	4
2.1	3715730	Bolzen	Bolt	Boulon	58.921-11-02.1		1	1
2.2	1429020	Sprengring	Snap ring	Anneau d'arrêt	DIN7993	A40	1	1
2.3	0015170	Schmiernippel	Grease nipple	Graisseur	DIN71412	AM8x1	1	1
2.4	3457060	Sicherung	Locking device	Plaque d'arrêt	58.725-11-00.2	55x19,5x6	1	1
2.5	2540420	Sechskantschraube	Screw	Vis	DIN933	M10x20 8.8VP	1	1
3	3722050	Stange	Rod	Barre	58.921-102-04-00.1		1	1
4	3722010	Stecker gsw.	Plug welded	Fiche soudée	58.921-102-04-02		1	--
4	3722040	Stecker gsw.	Plug welded	Fiche soudée	58.921-103-04-02		--	1
5	3722060	Steg	Link	Traverse	58.921-102-04-03		1	1
6	3737630	Anlage kpl. rechts	Adapter right cpl.	Adaptateur droit complet	58.921-102-04-04		1	1
6.1	3737650	Anlage rechts	Adapter right	Adaptateur droit	58.921-102-04-04-01		1	1
6.2	3482950	Miniraster	Lock pin	Axe de verrouillage			1	1
7	3737620	Anlage kpl. links	Adapter left cpl.	Adaptateur gauche complet	58.921-102-04-05		1	1
7.1	3737640	Anlage links	Adapter left	Adaptateur gauche	58.921-102-04-05-01		1	1
7.2	3482950	Miniraster	Lock pin	Axe de verrouillage			1	1
8	3350970	Druckfeder	Pressure spring	Ressort de verrouillage	58.420-21-00.1		2	2
9	0006410	Scheibe	Washer	Rondelle	DIN433	21	1	1
10	0013090	Spannstift	Pin	Goupille	ISO 8752	5x36	1	1
11	0297750	Sechskantschraube	Screw	Vis		M8x40 8.8	2	2
12	0200600	Sicherungsmütter	Nut	Ecrou		M8 8	2	2
13	3737710	Mutter	Nut	Ecrou	58.921-102-04-00.2		4	4
14	0497720	Zylinderschraube	Screw	Vis		M10x25 8.8VP	4	4
15A	3431550	Aufkleberbogen „Technik gelb“ für Europa: EU-Länder	Decal sheet "Technology yellow" for Europe: EC countries	Plaque d'autocollants « technique, jaune » pour Europe: pays membre UE			1	1
15B	3484230	Aufkleber Technik ASAE nur im Bereich der ASAE USA, Neuseeland, Australien	Decal "Technics" ASAE states only USA, New Zealand, Australia	Autocollant « technique » seulement pour les payes ASAE standard USA, Nouvelle Zélande, Australie			1	1

DE Hydraulischer Wechselrahmen
Euro-SMS

EN Hydraulic change frame Euro-
SMS

FR Cadre porte-outils hydraulique
Euro-SMS

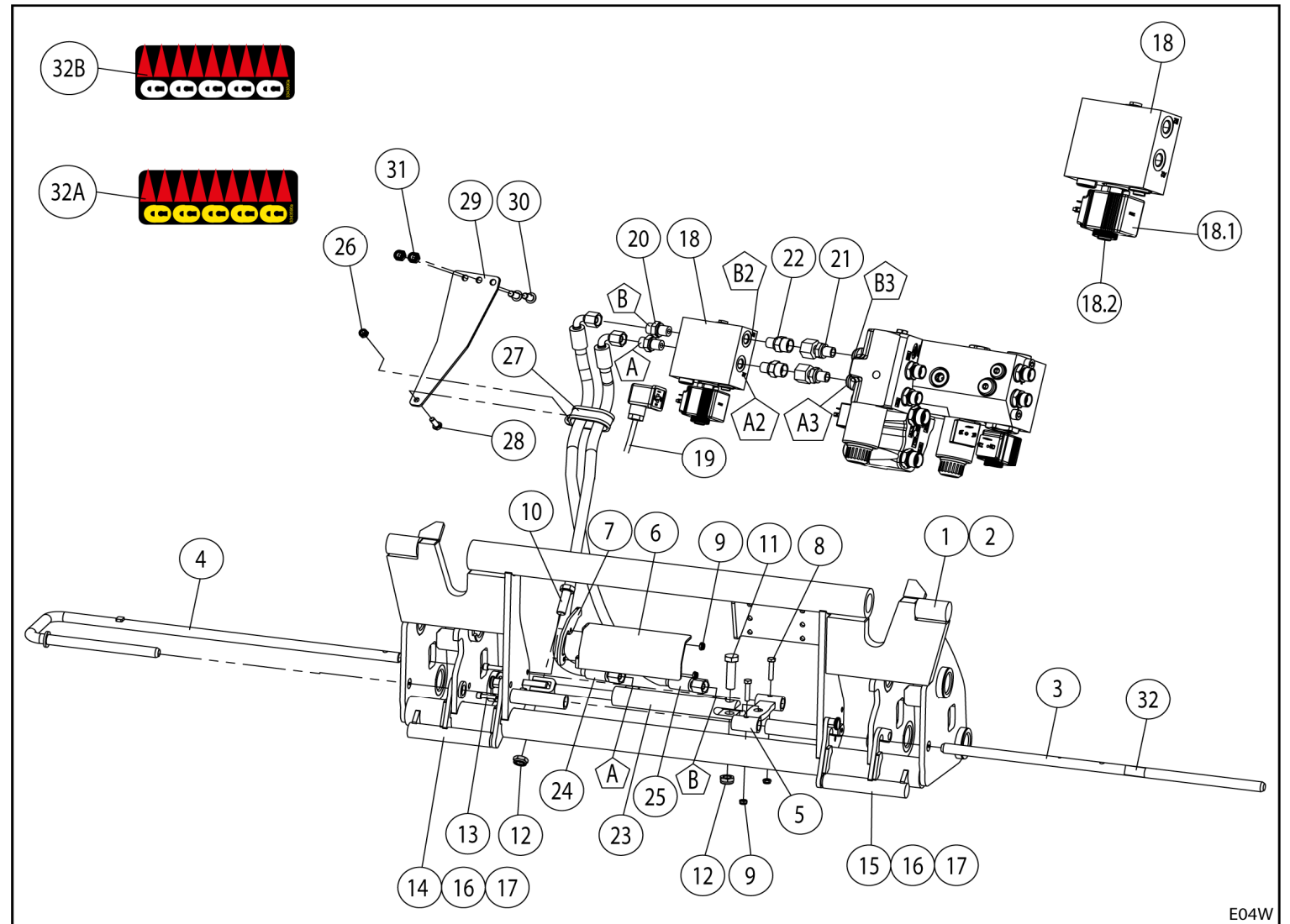

E04W

E04W		Hydraulischer Wechselrahmen Euro-SMS	Hydraulic change frame Euro-SMS	Cadre porte-outils hydraulique Euro-SMS				
Pos.	Bestell-Nr.	Benennung	Description	Désignation	Zeichnungs-Nr.	SIZE/MASS	FS/FZ 36-20 bis 43-34	FS/FZ 36-20.1 bis 48-42.1
1	3729000	Wechselrahmen	Change frame	Cadre porte-outils	58.921-102-04-01		1	-
1	3729060	Wechselrahmen	Change frame	Cadre porte-outils	58.921-103-04-01		--	1
2	3714620	Bolzen kpl.	Bolt cpl.	Boulon complet	58.921-11-02	40x143	4	4
2.1	3715730	Bolzen	Bolt	Boulon	58.921-11-02.1		1	1
2.2	1429020	Sprengring	Snap ring	Anneau d'arrêt	DIN7993	A40	1	1
2.3	0015170	Schmiernippel	Grease nipple	Graisser	DIN71412	AM8x1	1	1
2.4	3457060	Sicherung	Locking device	Plaque d'arrêt	58.725-11-00.2	55x19,5x6	1	1
2.5	2540420	Sechskantschraube	Screw	Vis	DIN933	M10x20 8.8VP	1	1
3	3722050	Stange	Rod	Barre	58.921-102-04-00.1		1	1
4	3722010	Stecker gsw.	Plug welded	Fiche soudée	58.921-102-04-02		1	--
4	3722040	Stecker gsw.	Plug welded	Fiche soudée	58.921-103-04-02		--	1
5	3722060	Steg	Link	Traverse	58.921-102-04-03		1	1
6	3739710	Schutzblech	Protective plate	Tôle de protection	58.921-202-04-00.1		1	1
7	3744660	Riegel	Latch	Verrou	58.921-202-04-00.2		1	1
8	0297750	Sechskantschraube	Screw	Vis		M8x40 8.8	2	2
9	0200600	Sicherungsmutter	Nut	Ecrou		M8 8	4	4
10	0010170	Sechskantschraube	Screw	Vis		M16x50 8.8	1	1
11	0010180	Sechskantschraube	Screw	Vis		M16x60 8.8	1	1
12	0412200	Sicherungsmutter	Nut	Ecrou		M16 8	2	2
13	0082560	Zylinderschraube	Screw	Vis		M8x30 8.8	2	2
14	3737630	Anlage kpl. rechts	Adapter right cpl.	Adaptateur droit complet	58.921-102-04-04		1	1
14.1	3737650	Anlage rechts	Adapter right	Adaptateur droit	58.921-102-04-04-01		1	1
14.2	3482950	Miniraster	Lock pin	Axe de verrouillage			1	1
15	3737620	Anlage kpl. links	Adapter left cpl.	Adaptateur gauche complet	58.921-102-04-05		1	1
15.1	3737640	Anlage links	Adapter left	Adaptateur gauche	58.921-102-04-05-01		1	1
15.2	3482950	Miniraster	Lock pin	Axe de verrouillage			1	1
16	3737710	Mutter	Nut	Ecrou	58.921-102-04-00.2		4	4
17	0497720	Zylinderschraube	Screw	Vis		M10x25 8.8VP	4	4
18	1439840	Ventilblock WZV 140 bar	Valve block 140 bar	Bloc hydraulique 140 bar	58.725-19-07-02		1	1
18.1	1432520	Gleichstrommagnet	Magnet	Bobine			1	1
18.2	1432510	Patrone 3/2-Wege	Cartridge	Cartouche			1	1
19	3466790	Anschlusskabel Ventil kpl	Connection cable valve	Câble de raccordement valve	58.725-19-03-11	400 mm	1	1

DE Hydraulischer Wechselrahmen
Euro-SMS

EN Hydraulic change frame Euro-
SMS

FR Cadre porte-outils hydraulique
Euro-SMS

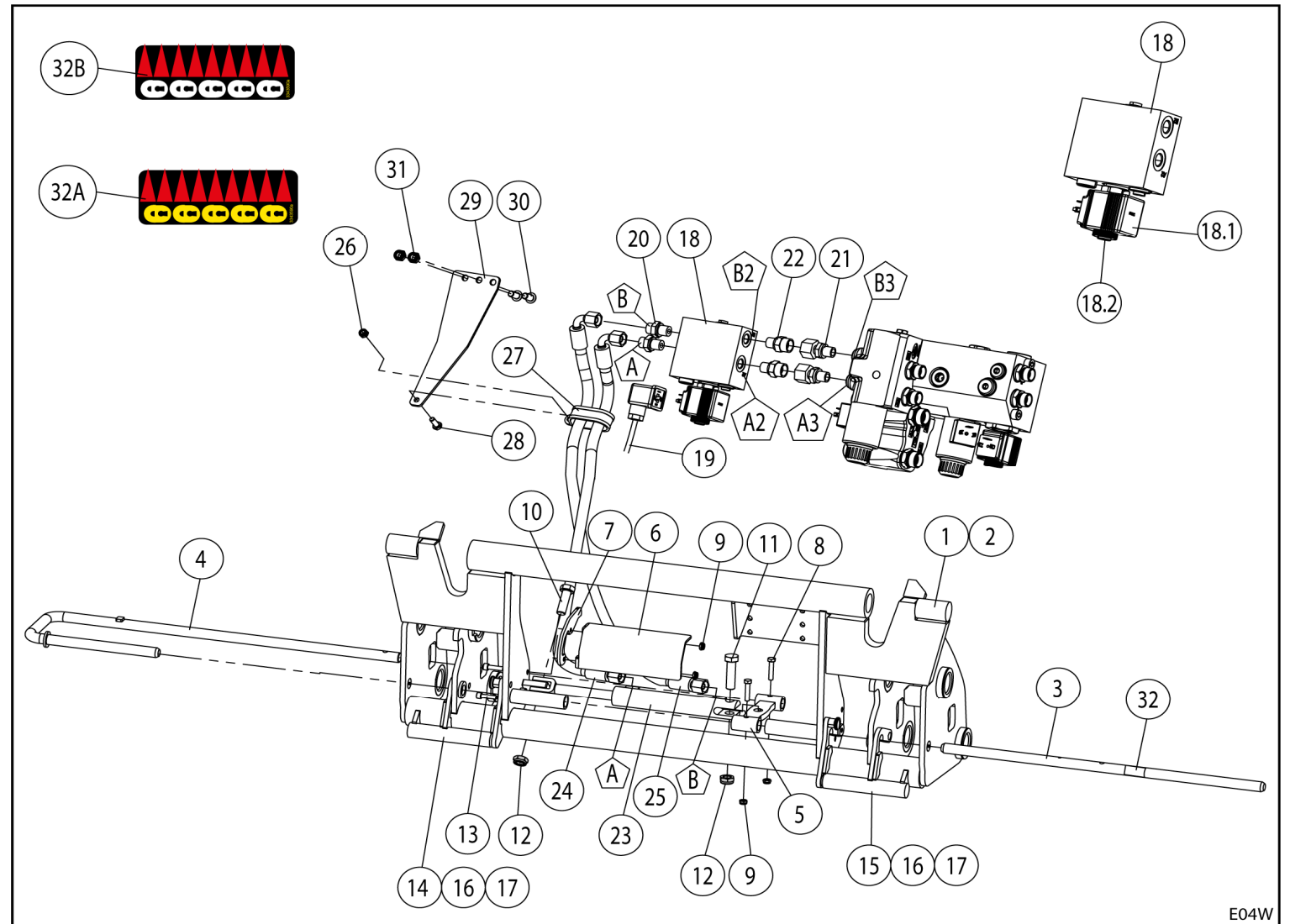

E04W

E04W		Hydraulischer Wechselrahmen Euro-SMS	Hydraulic change frame Euro-SMS	Cadre porte-outils hydraulique Euro-SMS				
Pos.	Bestell-Nr.	Benennung	Description	Désignation	Zeichnungs-Nr.	SIZE/MASS	FS/FZ 36-20 bis 43-34	FS/FZ 36-20.1 bis 48-42.1
20	0428821	Gerader Einschraubstutzen	Screwed connection	Raccord droit		WA GES 8 LR A3L	2	2
21	0453910	Gerader Einschraubstutzen	Screwed connection	Raccord droit		WA EGESD 12LR1/4WD A3L	2	2
22	0455770	Gerader Einschraubstutzen	Screwed connection	Raccord droit		WA GES 12 LR1/4 A3L	2	2
23	3622280	Hydrozylinder	Cylinder	Vérin	58.02-199	32/20/100/270	1	1
23.1	3576530	Dichtsatz	Seal kit	Jeu de joints	58.02-118-01 E		1	1
24	1420820	Schlauchleitung	Hose line	Flexible		6x750 R8 A RKA45	1	--
24	3741700	Schlauchleitung	Hose line	Flexible		6x800 R8 N RKN90	--	1
25	1440010	Schlauchleitung	Hose line	Flexible		6x900 R8 N RKN45	1	--
25	1442420	Schlauchleitung	Hose line	Flexible		6x950 R8 N RKN90	--	1
26	0412570	Sicherungsmutter	Nut	Ecrou		M6 8	1	1
27	2481270	Rohrschelle	Pipe clamp	Attache de tuyau		1.2x23/15-W1	1	1
28	0011070	Sechskantschraube	Screw	Vis		M6x25 8.8	1	1
29	3741690	Halter	Support	Support	58.921-202-01-01-00.1		1	1
30	1442230	Flachkopfschraube	Screw	Vis		M8x16 10.9	2	2
31	0200600	Sicherungsmutter	Self locking nut	Ecrou autofreiné		M8 8	2	2
32A	3431550	Aufkleberbogen „Technik gelb“	Decal sheet "Technology yellow"	Plaque d'autocollants « technique, jaune »			1	1
		<i>für Europa: EU-Länder</i>	<i>for Europe: EC countries</i>	<i>pour Europe: pays membre UE</i>				
32B	3484230	Aufkleber Technik ASAE	Decal "Technics"	Autocollant « technique »			1	1
		<i>nur im Bereich der ASAE</i>	<i>ASAE states only</i>	<i>seulement pour les payes ASAE standard</i>				
		<i>USA, Neuseeland, Australien</i>	<i>USA, New Zealand, Australia</i>	<i>USA, Nouvelle Zélande, Australie</i>				

DE Mechanischer Wechselrahmen
Euro-Alö3

EN Mechanical change frame Euro-
Alö3

FR Cadre porte-outils mécanique
Euro-Alö3

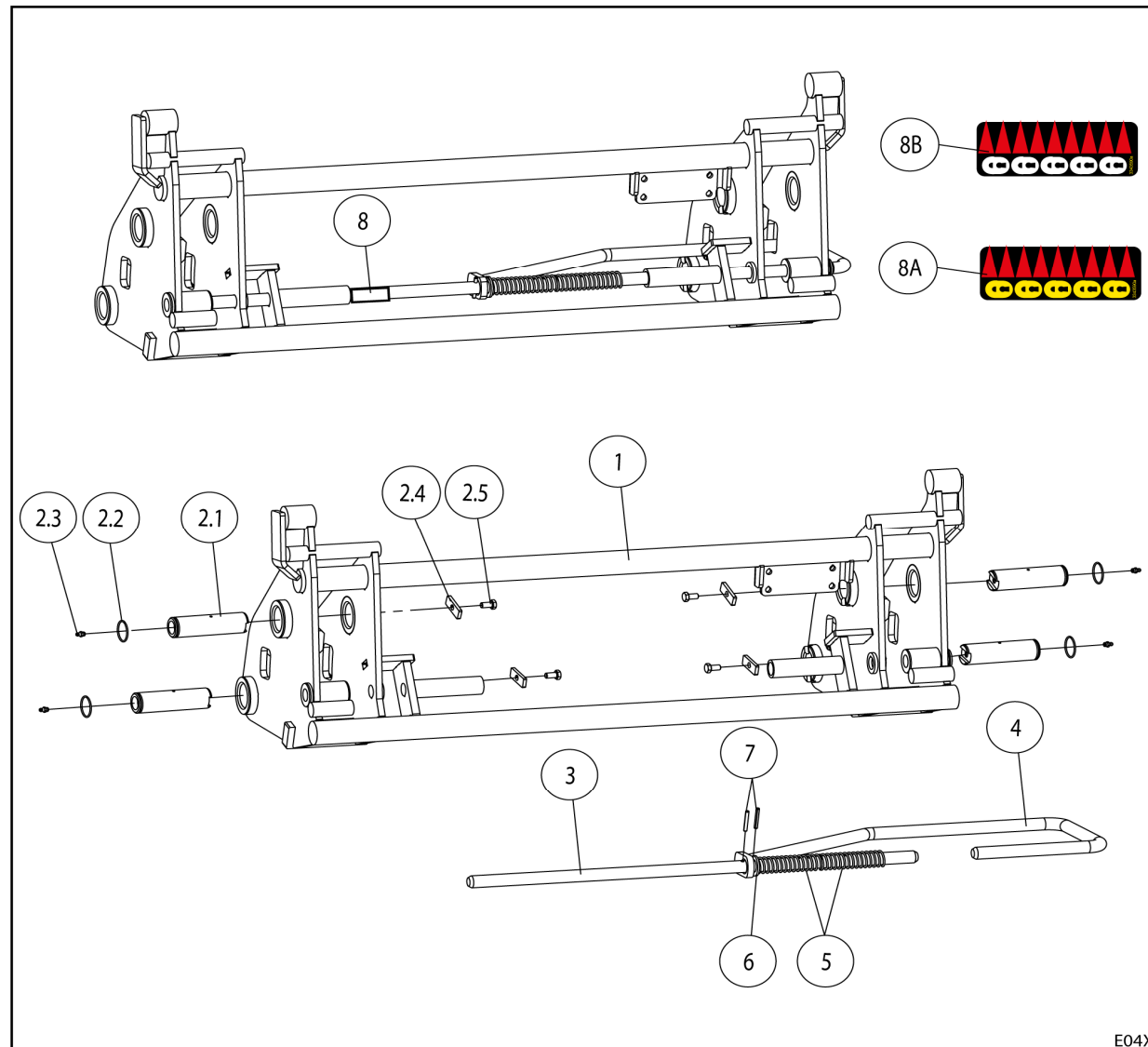

E04X		Mechanischer Wechselrahmen Euro-AIö3	Mechanical change frame Euro-AIö3	Cadre porte-outils mécanique Euro-AIö3				
Pos.	Bestell-Nr.	Benennung	Description	Désignation	Zeichnungs-Nr.	SIZE/MASS	FS/FZ 36-20 bis 43-34	FS/FZ 36-20.1 bis 48-42.1
1	3729400	Wechselrahmen	Change frame	Cadre porte-outils	58.921-102-05-01		1	-
1	3729630	Wechselrahmen	Change frame	Cadre porte-outils	58.921-103-05-01		-	1
2	3714620	Bolzen kpl.	Bolt cpl.	Boulon complet	58.921-11-02	40x143	4	4
2.1	3715730	Bolzen	Bolt	Boulon	58.921-11-02.1		1	1
2.2	1429020	Sprengring	Snap ring	Anneau d'arrêt	DIN7993	A40	1	1
2.3	0015170	Schmiernippel	Grease nipple	Graisser	DIN71412	AM8x1	1	1
2.4	3457060	Sicherung	Locking device	Plaque d'arrêt	58.725-11-00.2	55x19,5x6	1	1
2.5	2540420	Sechskantschraube	Screw	Vis	DIN933	M10x20 8.8VP	1	1
3	3619370	Stange	Rod	Barre	58.725-02-00.2		1	1
4	3722070	Stecker gsw.	Plug welded	Fiche soudée	58.921-102-05-02		1	--
4	3722080	Stecker gsw.	Plug welded	Fiche soudée	58.921-103-05-02		--	1
5	3350970	Druckfeder	Pressure spring	Ressort de verrouillage	58.420-21-00.1		2	2
6	0006410	Scheibe	Washer	Rondelle	DIN433	21	1	1
7	0013090	Spannstift	Pin	Goupille	ISO 8752	5x36	2	2
8A	3431550	Aufkleberbogen „Technik gelb“ <i>für Europa: EU-Länder</i>	Decal sheet "Technology yellow" <i>for Europe: EC countries</i>	Plaque d'autocollants « technique, jaune » <i>pour Europe: pays membre UE</i>			1	1
8B	3484230	Aufkleber Technik ASAE <i>nur im Bereich der ASAE</i> <i>USA, Neuseeland, Australien</i>	Decal "Technics" <i>ASAE states only</i> <i>USA, New Zealand, Australia</i>	Autocollant « technique » <i>seulement pour les payes ASAE standard</i> <i>USA, Nouvelle Zélande, Australie</i>			1	1

DE Mechanischer Wechselrahmen
Skid-Steer

EN Mechanical change frame Skid-
Steer

FR Cadre porte-outils mécanique
Skid-Steer

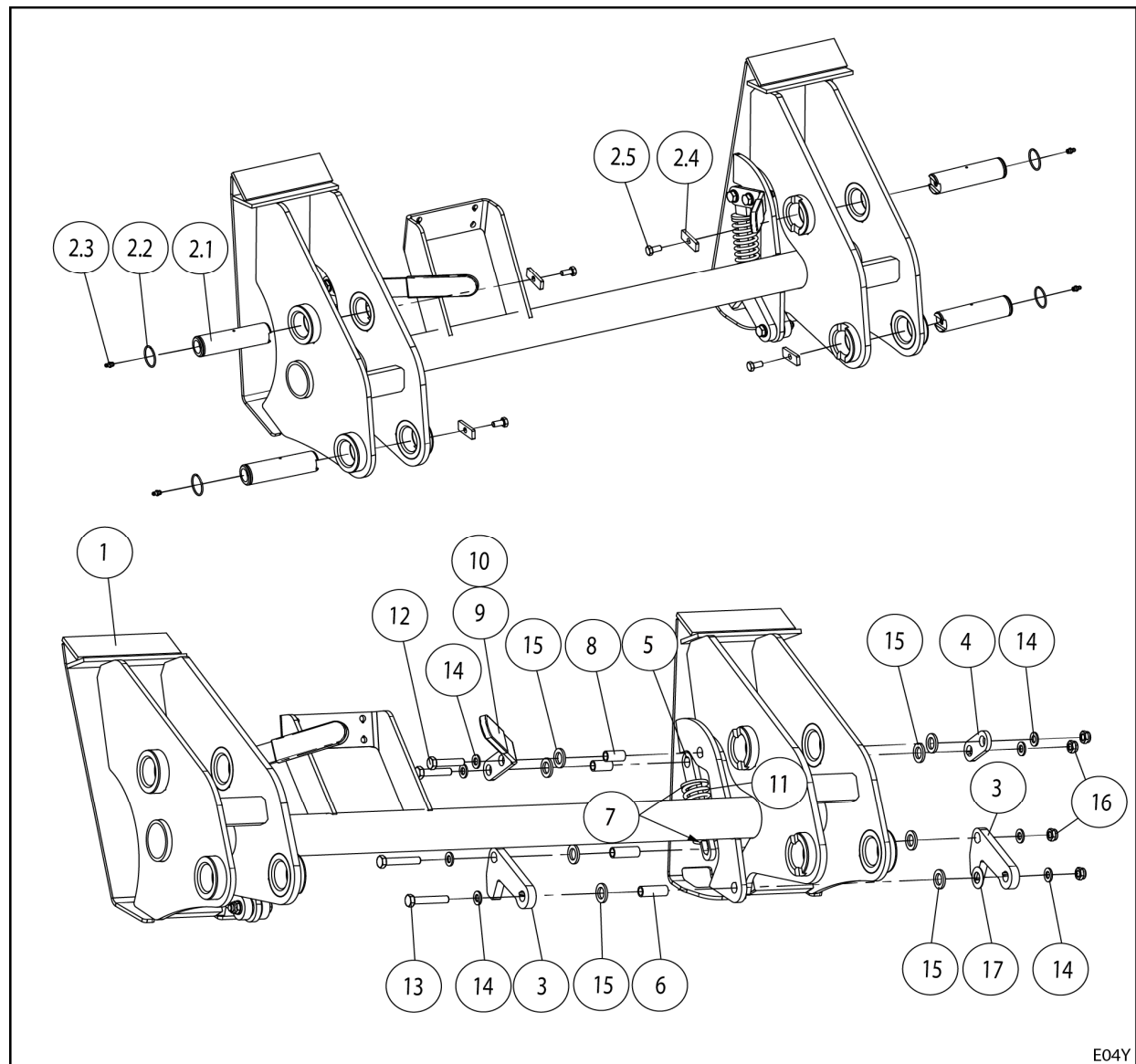

E04Y

E04Y		Mechanischer Wechselrahmen Skid-Steer	Mechanical change frame Skid-Steer	Cadre porte-outils mécanique Skid-Steer			
Pos.	Bestell-Nr.	Benennung	Description	Désignation	Zeichnungs-Nr.	SIZE/MASS	FS/FZ 36-20 bis 39-31
1	3729240	Wechselrahmen	Change frame	Cadre porte-outils	58.921-102-06-01		1
2	3714620	Bolzen kpl.	Bolt cpl.	Boulon complet	58.921-11-02	40x143	4
2.1	3715730	Bolzen	Bolt	Boulon	58.921-11-02.1		1
2.2	1429020	Sprengring	Snap ring	Anneau d'arrêt	DIN7993	A40	1
2.3	0015170	Schmiernippel	Grease nipple	Graisseur	DIN71412	AM8x1	1
2.4	3457060	Sicherung	Locking device	Plaque d'arrêt	58.725-11-00.2	55x19,5x6	1
2.5	2540420	Sechskantschraube	Screw	Vis	DIN933	M10x20 8.8VP	1
3	3644840	Haken	Hook	Crochet	58.765-02-00.10		4
4	3493470	Lasche	Latch	Languette	58.765-02-00.2		2
5	3493480	Koppelstange	Rod	Barre	58.765-02-00.3		2
6	3644850	Buchse	Bush	Douille	58.765-02-00.14		4
7	3493500	Scheibe	Washer	Rondelle	58.765-02-00.5		4
8	3493510	Buchse	Bush	Douille	58.765-02-00.6		4
9	3493520	Hebel	Lever	Levier	58.765-02-00.7		2
10	1427780	Handschutzkappe	Protective cap	Capuchon			2
11	1431910	Druckfeder	Pressure spring	Ressort de verrouillage	GUKU VD-356 A	5x32x94	2
12	0071620	Sechskantschraube	Screw	Vis	DIN931	M10x45 8.8	4
13	0009400	Sechskantschraube	Screw	Vis	DIN931	M10x55 8.8	4
14	0407400	Scheibe	Washer	Rondelle	DIN125	A10,5	16
15	0011990	Scheibe	Washer	Rondelle	DIN1441	17	16
16	0011940	Sicherungsmutter	Nut	Ecrou	DIN985	NM10 8	8
17	0453520	Tellerfeder	Cup spring	Rondelle ressort	MUBEA	31,5x16,5x0,8	2

DE Mechanischer Wechselrahmen
Euro-MX

EN Mechanical change frame Euro-
MX

FR Cadre porte-outils mécanique
Euro-MX

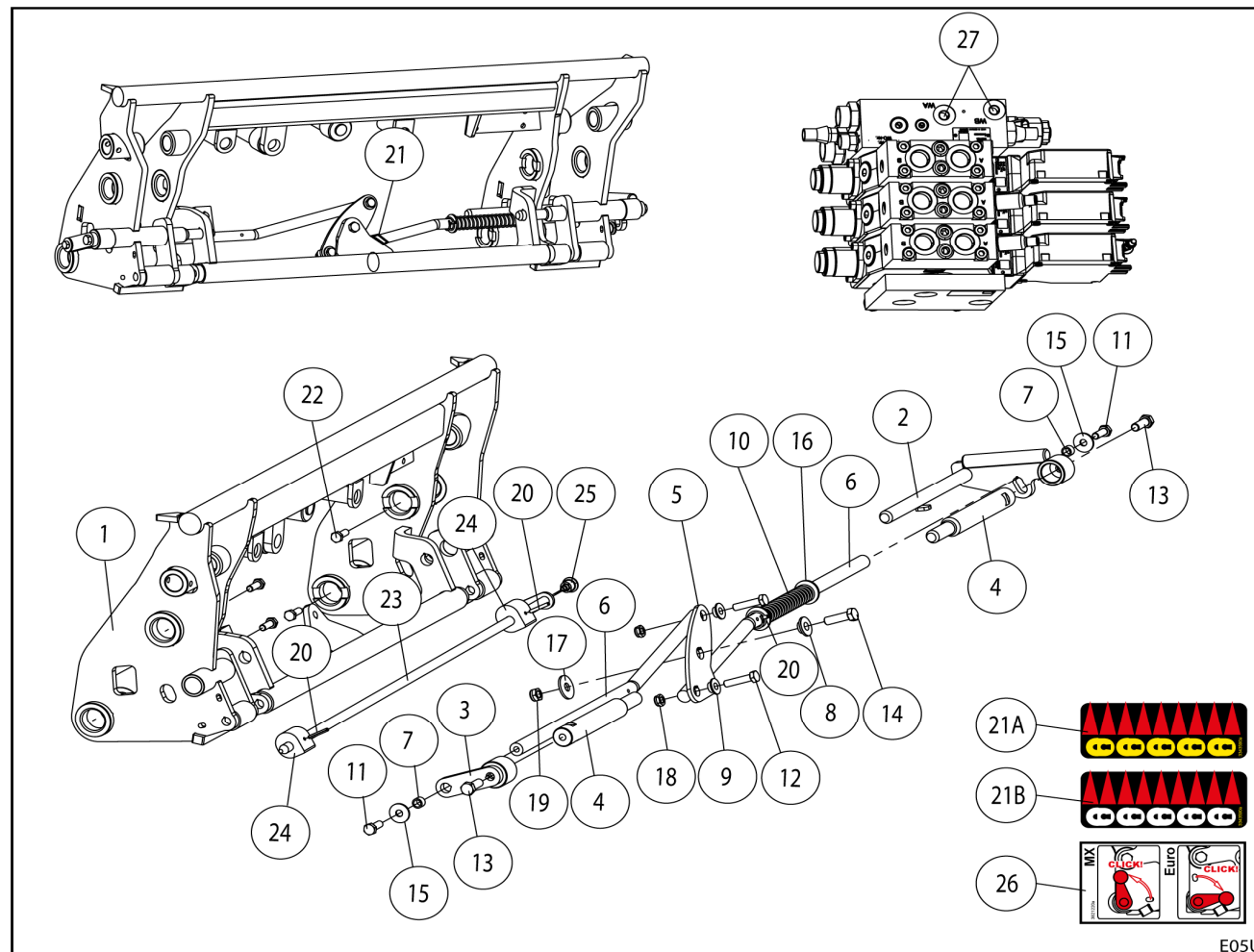

E05U		Mechanischer Wechselrahmen Euro-MX	Mechanical change frame Euro-MX	Cadre porte-outils mécanique Euro-MX					
Pos.	Bestell-Nr.	Benennung	Description	Désignation	Zeichnungs-Nr.	SIZE/MASS	FS/FZ 36-20 bis 43-34	FS/FZ 36-20.1 bis 48-42.1	FS/FZ IB+ 41-25.1 bis 48-42.1
1	3790750	Wechselrahmen	Change frame	Cadre porte-outils	58.921-102-07-01		1	--	--
1	3786810	Wechselrahmen	Change frame	Cadre porte-outils	58.921-103-07-01		--	1	1
2	3790930	Griff	Handle	Poignée	58.921-102-07-02		1	--	--
2	3787230	Griff	Handle	Poignée	58.921-103-07-02		--	1	1
3	3787250	Riegel	Latch	Verrou	58.921-102-07-03		1	1	1
4	3790910	Verriegelungsstecker	Lock connector	Axe de verrouillage	58.921-102-07-00.1		2	--	--
4	3787170	Verriegelungsstecker	Lock connector	Axe de verrouillage	58.921-103-07-00.1		--	2	2
5	3787160	Stellscheibe	Setting disc	Disque de réglage	58.921-102-07-00.2		1	1	1
6	3790920	Stange	Rod	Barre	58.921-102-07-00.3		2	--	--
6	3787180	Stange	Rod	Barre	58.921-103-07-00.3		--	2	2
7	3787190	Buchse	Bush	Douille	58.921-102-07-00.4		2	2	2
8	3788690	Lager Stellscheibe	Setting disc bearing	Roulement disque de réglage	58.921-102-07-00.5	30 mm	1	1	1
9	3788710	Lager Stange	Rod bearing	Roulement barre	58.921-102-07-00.6	25 mm	2	2	2
10	3665240	Druckfeder	Pressure spring	Ressort de verrouillage	58.725-102-08-00.8		1	1	1
11	1412570	Sechskantschraube	Screw	Vis		M10x30 8.8VP	2	2	2
12	0010710	Sechskantschraube	Screw	Vis		M10x45 8.8	2	2	2
13	1406300	Sechskantschraube	Screw	Vis		M12x35 8.8VP	2	2	2
14	0202270	Sechskantschraube	Screw	Vis		M12x40 8.8	1	1	1
15	0014110	Scheibe	Washer	Rondelle		A10,5	2	2	2
16	0294640	Scheibe	Washer	Rondelle		A21	2	2	2
17	0014070	Scheibe	Washer	Rondelle		A13x37x3	1	1	1
18	0011940	Sicherungsmutter	Nut	Ecrou		M10 8	2	2	2
19	0200610	Sicherungsmutter	Nut	Ecrou		M12 8	1	1	1
20	0013090	Spannstift	Pin	Goupille		5x36	3	3	3
21A	3431550	Aufkleberbogen „Technik gelb“ für Europa: EU-Länder	Decal sheet "Technology yellow" for Europe: EC countries	Plaque d'autocollants « technique, jaune » pour Europe: pays membre UE			1	1	1
21B	3484230	Aufkleber Technik ASAE nur im Bereich der ASAE	Decal "Technics" ASAE states only	Autocollant « technique » seulement pour les pays ASAE standard			1	1	1
22	2540420	Sechskantschraube	Screw	Vis		M10x20 8.8VP	4	4	4
23	3815870	Drehwelle	Turning shaft	Arbre rotatif	58.921-102-07-04		1	--	--
23	3815880	Drehwelle	Turning shaft	Arbre rotatif	58.921-103-07-04		--	1	1
24	3820160	Anschlag unten	Lower stop	Butée en bas	58.921-102-07-00.7		2	2	2
25	3482950	Miniraster	Lock pin	Axe de verrouillage			1	1	1
26	3821220	Aufkleber „Raster Euro-MX“	"Lever Euro-MX" sticker	Autocollant « Cliquet Euro-MX »			1	1	1
27	0496670	Verschlusschraube	Locking screw	Vis de fermeture			--	--	2

DE Hydraulischer Wechselrahmen
Euro-MX

EN Hydraulic change frame Euro-MX

FR Cadre porte-outils hydraulique
Euro-MX

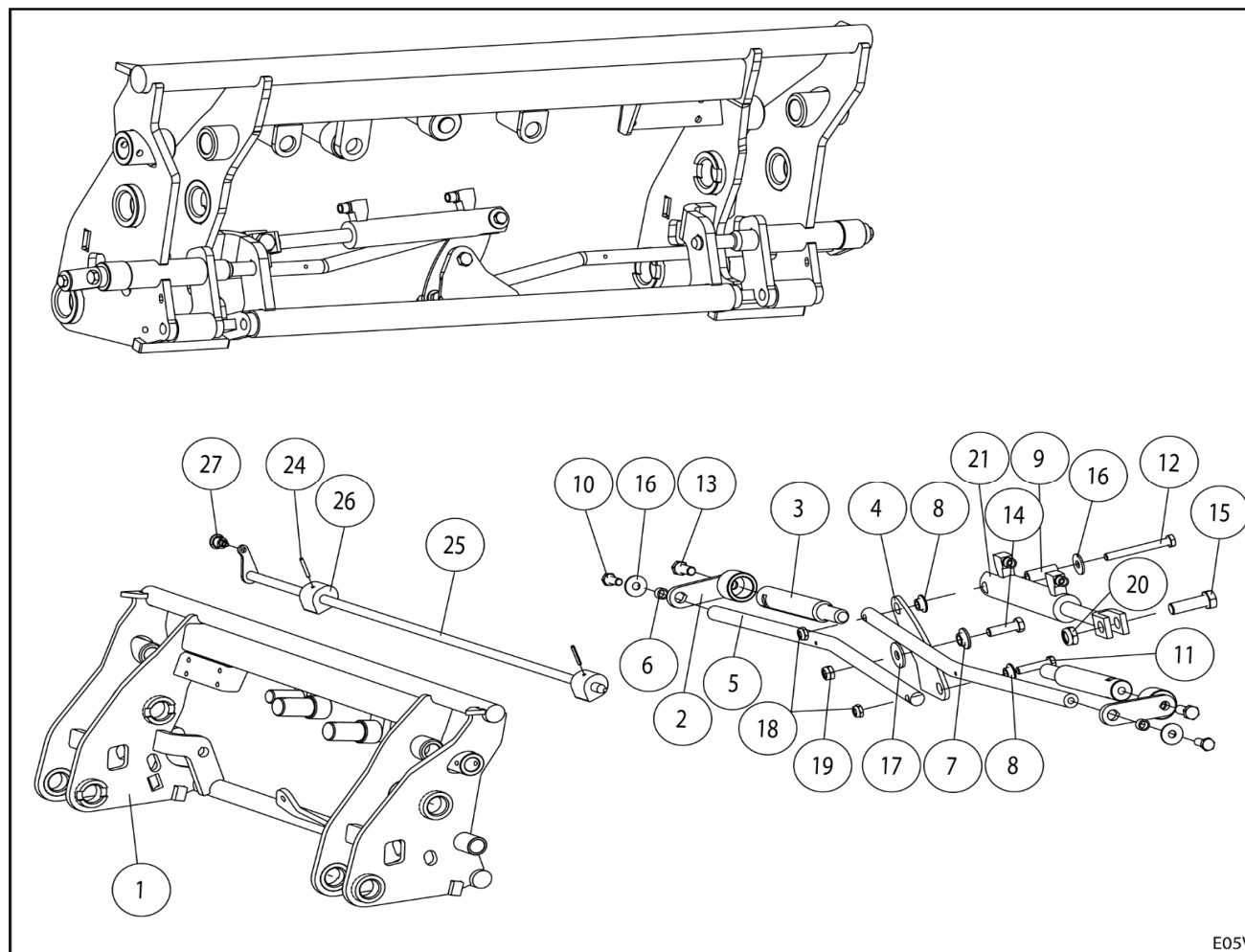

E05V

E05V+E05X		Hydraulischer Wechselrahmen Euro-MX	Hydraulic change frame Euro-MX	Cadre porte-outils hydraulique Euro-MX					
Pos.	Bestell-Nr.	Benennung	Description	Désignation	Zeichnungs-Nr.	SIZE/MASS	FS/FZ 36-20 bis 43-34	FS/FZ 36-20.1 bis 48-42.1	FS/FZ IB+ 41-25.1 bis 48-42.1
1	3790750	Wechselrahmen	Change frame	Cadre porte-outils	58.921-102-07-01		1	--	--
1	3786810	Wechselrahmen	Change frame	Cadre porte-outils	58.921-103-07-01		--	1	1
2	3787250	Riegel	Latch	Verrou	58.921-102-07-03		2	2	2
3	3790910	Verriegelungsstecker	Lock connector	Axe de verrouillage	58.921-102-07-00.1		2	--	--
3	3787170	Verriegelungsstecker	Lock connector	Axe de verrouillage	58.921-103-07-00.1		--	2	2
4	3787160	Stellscheibe	Setting disc	Disque de réglage	58.921-102-07-00.2		1	1	1
5	3790920	Stange	Rod	Barre	58.921-102-07-00.3		2	--	--
5	3787180	Stange	Rod	Barre	58.921-103-07-00.3		--	2	2
6	3787190	Buchse	Bush	Douille	58.921-102-07-00.4		2	2	2
7	3788690	Lager Stellscheibe	Setting disc bearing	Roulement disque de réglage	58.921-102-07-00.5	30 mm	1	1	1
8	3788710	Lager Stange	Rod bearing	Roulement barre	58.921-102-07-00.6	25 mm	2	2	2
9	3787260	Buchse	Bush	Douille	58.921-202-07-00.6		1	1	1
10	1412570	Sechskantschraube	Screw	Vis		M10x30 8.8VP	2	2	2
11	0010710	Sechskantschraube	Screw	Vis		M10x45 8.8	1	1	1
12	0297770	Sechskantschraube	Screw	Vis		M10x90 8.8	1	1	1
13	1406300	Sechskantschraube	Screw	Vis		M12x35 8.8VP	2	2	2
14	0202270	Sechskantschraube	Screw	Vis		M12x40 8.8	1	1	1
15	0202350	Sechskantschraube	Screw	Vis		M16x50 8.8	1	1	1
16	0014110	Scheibe	Washer	Rondelle		A10,5	3	3	3
17	0014070	Scheibe	Washer	Rondelle		A13x37x3	1	1	1
18	0011940	Sicherungsmutter	Nut	Ecrou		M10 8	2	2	2
19	0200610	Sicherungsmutter	Nut	Ecrou		M12 8	1	1	1
20	0412200	Sicherungsmutter	Nut	Ecrou		M16 8	1	1	1
21	3622280	Hydrozylinder	Cylinder	Vérin	58.02-199	32/20/100/270	1	1	1
21.1	3576530	Dichtsatz	Seal kit	Jeu de joints	58.02-118-01 E		1	1	1
22	1420820	Schlauchleitung	Hose line	Flexible		6x750 R8 A RKA45	1	--	--
22	3741700	Schlauchleitung	Hose line	Flexible		6x800 R8 N RKN90	--	1	--
22	1445540	Schlauchleitung	Hose line	Flexible		6x750 R8 AD	--	--	1
23	1440010	Schlauchleitung	Hose line	Flexible		6x900 R8 N RKN45	1	--	--
23	1442420	Schlauchleitung	Hose line	Flexible		6x950 R8 N RKN90	--	1	--
23	1445550	Schlauchleitung	Hose line	Flexible		6x850 R8 AD	--	--	1
24	0013090	Spannstift	Pin	Goupille		5x36	2	2	2
25	3815870	Drehwelle	Turning shaft	Arbre rotatif	58.921-102-07-04		1	--	--
25	3815880	Drehwelle	Turning shaft	Arbre rotatif	58.921-103-07-04		--	1	1
26	3820160	Anschlag unten	Lower stop	Butée en bas	58.921-102-07-00.7		2	2	2
27	3482950	Miniraster	Lock pin	Axe de verrouillage			1	1	1

DE Hydraulischer Wechselrahmen
Euro-MX

EN Hydraulic change frame Euro-MX

FR Cadre porte-outils hydraulique
Euro-MX

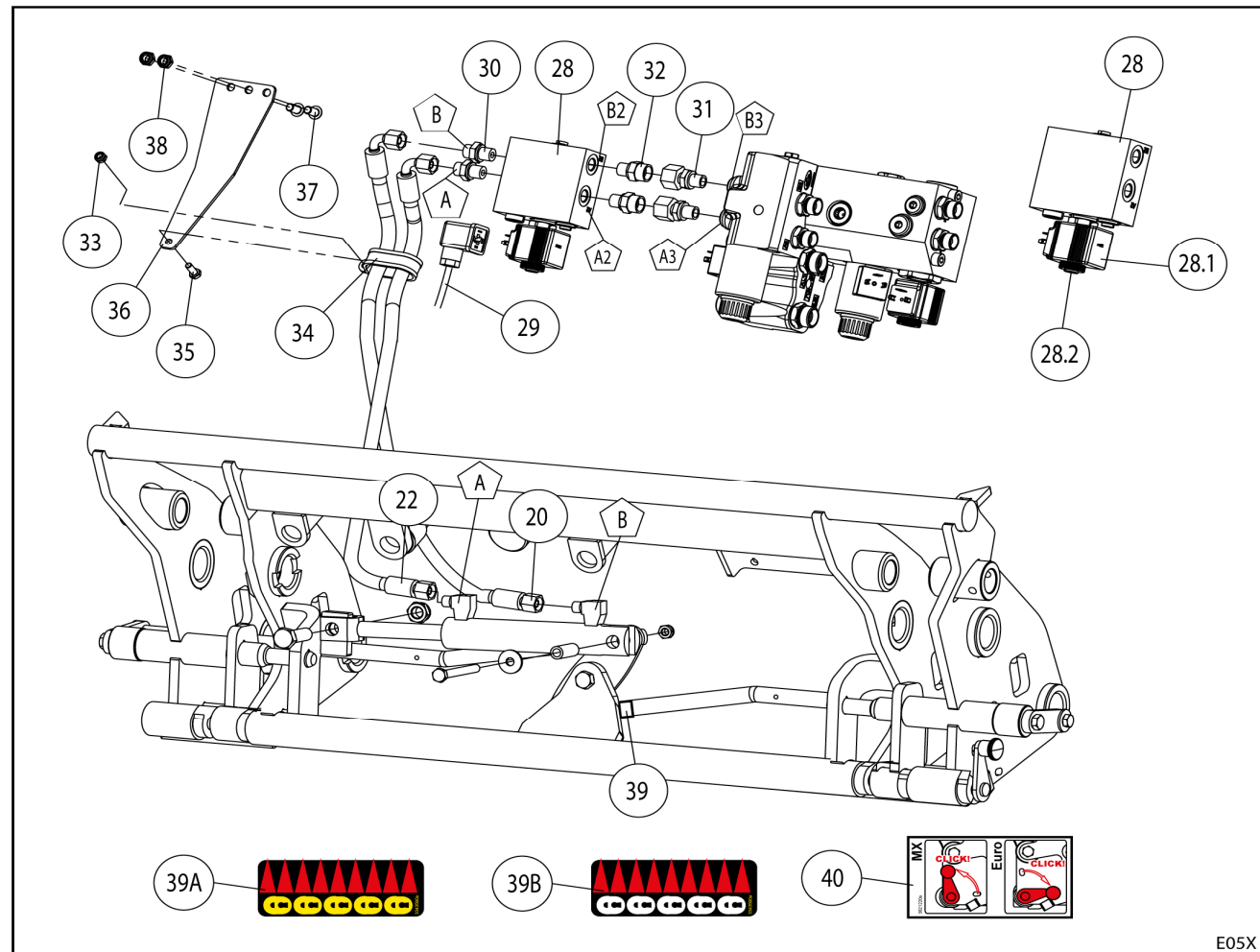

E05X

E05V+E05X		Hydraulischer Wechselrahmen Euro-MX	Hydraulic change frame Euro-MX	Cadre porte-outils hydraulique Euro-MX					
Pos.	Bestell-Nr.	Benennung	Description	Désignation	Zeichnungs-Nr.	SIZE/MASS	FS/FZ 36-20 bis 43-34	FS/FZ 36-20.1 bis 48-42.1	FS/FZ IB+ 41-25.1 bis 48-42.1
28	1439840	Ventilblock WZV 140 bar	Valve block 140 bar	Bloc hydraulique 140 bar	58.725-19-07-02		1	1	
28.1	1432520	Gleichstrommagnet	Magnet	Bobine			1	1	
28.2	1432510	Patrone 3/2-Wege	Cartridge	Cartouche			1	1	
29	3466790	Anschlusskabel Ventil kpl	Connection cable valve	Câble de raccordement valve	58.725-19-03-11	400 mm	1	1	
30	0428821	Gerader Einschraubstutzen	Screwed connection	Raccord droit		WA GES 8 LR A3L	2	2	
31	0453910	Gerader Einschraubstutzen	Screwed connection	Raccord droit		ESD 12LR1/4WD A3L	2	2	
32	0455770	Gerader Einschraubstutzen	Screwed connection	Raccord droit		WA GES 12 LR1/4 A3L	2	2	
33	0412570	Sicherungsmutter	Nut	Ecrou		M6 8	1	1	
34	2481270	Rohrschelle	Pipe clamp	Attache de tuyau		1.2x23/15-W1	1	1	
35	0011070	Sechskantschraube	Screw	Vis		M6x25 8.8	1	1	
36	3741690	Halter	Support	Support	58.921-202-01-01-00.1		1	1	
37	1442230	Flachkopfschraube	Screw	Vis		M8x16 10.9	2	2	
38	0200600	Sicherungsmutter	Self locking nut	Ecrou autofreiné		M8 8	2	2	
39A	3431550	Aufkleberbogen „Technik gelb“	Decal sheet "Technology yellow"	Plaque d'autocollants « technique, jaune			1	1	1
		für Europa: EU-Länder	for Europe: EC countries	pour Europe: pays membre UE					
39B	3484230	Aufkleber Technik ASAE	Decal "Technics"	Autocollant « technique »			1	1	1
		nur im Bereich der ASAE	ASAE states only	seulement pour les payes ASAE standard					
40	3821220	Aufkleber „Raster Euro-MX“	"Lever Euro-MX" sticker	Autocollant « Cliquet Euro-MX »			1	1	1

siehe Ersatzteilliste ProfiLine E58FZ2
 see Spare parts list ProfiLine E58FZ2
 voir Liste des pièces de rechange ProfiLine E58FZ2

DE Adapter Euro-MX

EN Adapter Euro-MX

FR Adaptateur Euro-MX

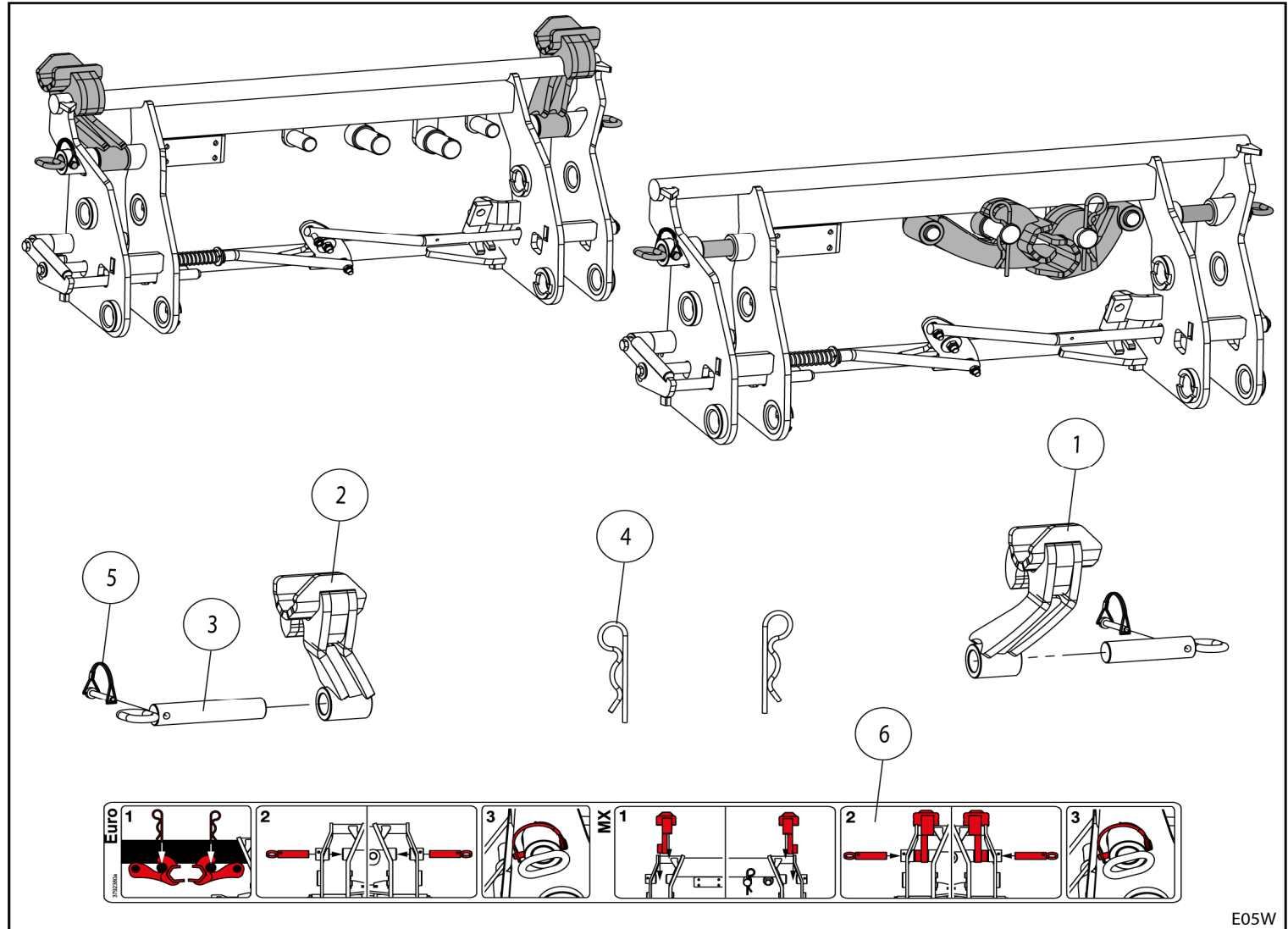

E05W

E05W		Adapter Euro-MX	Adapter Euro-MX	Adaptateur Euro-MX				
Pos.	Bestell-Nr.	Benennung	Description	Désignation	Zeichnungs-Nr.	SIZE/MASS	FS/FZ 36-20 bis 43-34	FS/FZ 36-20.1 bis 48-42.1
1	3790950	Werkzeugadapter links	Left implement adapter	Adaptateur à outils gauche	58.921-102-07-05-01		1	-
1	3787100	Werkzeugadapter links	Left implement adapter	Adaptateur à outils gauche	58.921-103-07-05-01		--	1
2	3791000	Werkzeugadapter rechts	Rght implement adapter	Adaptateur à outils droit	58.921-102-07-05-02		1	--
2	3787110	Werkzeugadapter rechts	Rght implement adapter	Adaptateur à outils droit	58.921-103-07-05-02		--	1
3	3791020	Verriegelungsbolzen	Locking pin	Boulon de verrouillage	58.921-102-07-05-03		2	--
3	3787120	Verriegelungsbolzen	Locking pin	Boulon de verrouillage	58.921-103-07-05-03		--	2
4	0184500	Federstecker	Spring clip	Fiche a ressort			2	2
5	3784700	Rohrklappsplint	Tube linch pin	Goupille tubulaire rabattable			2	2
6	3792380	Aufkleber „Adapter Euro-MX“	"Adapter Euro-MX" sticker	Autocollant « Adaptateur Euro-MX »			1	1

Anzugsmomente für Schrauben / Tightening torques for screws / Couples de serrage pour les vis

Gewinde / Thread / Filetage	Festigkeitsklasse / Strength category / Classe de résistance					
	8.8		10.9		12.09	
	Nm	lb-ft	Nm	lb-ft	Nm	lb-ft
M8	27	20	36	27	42	31
M8x1	29	21	38	28	45	33
M10	54	40	71	52	83	61
M10x1,25	57	42	75	55	87	64
M12	93	69	123	91	144	106
M12x1,5	97	72	128	94	150	111
M12x1,25	101	74	133	98	155	114
M14	148	109	195	144	229	169
M14x1,5	159	117	209	154	244	180
M16	230	170	302	223	354	261
M16x1,5	244	180	320	236	374	276
M18	329	243	421	311	492	363
M18x2	348	257	443	327	519	383
M18x1,5	368	271	465	343	544	401
M20	464	342	592	437	692	510
M20x2	488	360	619	457	724	534
M20x1,5	511	377	646	476	756	558
M22	634	468	807	595	945	697
M22x2	663	489	840	620	984	726
M22x1,5	692	510	873	644	1022	754
M24	798	589	1017	750	1190	878
M24x2	865	638	1095	808	1282	946
M27	1176	867	1496	1103	1750	1291
M27x2	1262	931	1594	1176	1866	1376
M30	1597	1178	2033	1499	2380	1755
M30x2	1756	1295	2216	1634	2594	1913
5/8" UNC (normal)	230	170	302	223		
5/8" UNF (fein)	244	180	320	236		
3/4" UNC (normal)	464	342	592	437		
3/4" UNF (fein)	511	377	646	476		



Auf die Sauberkeit der Gewinde achten! Die angegebenen Anzugsmomente gelten für saubere, trockene und fettfreie Schrauben und Gewinde.



Make sure that the thread is clean! The specified tightening torques are valid for screws and threads that are clean, dry and free of grease.



Veillez à la propreté des filetages ! Les couples de serrage indiqués ici s'appliquent à des vis et des filetages propres, secs et sans graisse.

Wilhelm STOLL
Maschinenfabrik GmbH
Bahnhofstr. 21 D-38268 Lengede

Ersatzteilbestellung / Spare parts order / Commande des pièces:

Tel.: +49 (0) 53 44 / 20 444

Fax: +49 (0) 53 44 / 20 183

Öffnungszeiten / business hours / heures d'ouverture:

Mo - Do / Mon - Thu / Lu - Je: 8:00 - 11:45 + 12:15 - 17:00

Fr / Fri / Ve: 8:00 - 11:45 + 12:15 - 16:00

Weitere Kontakte / further contacts / autres contacts:

Tel. Kundendienst / service / service: +49 (0) 5344 / 20 111

Fax Kundendienst / service / service: +49 (0) 5344 / 20 137

E-mail Kundendienst / service / service: service@stoll-germany.com

Fax Vertrieb / sales / vente: +49 (0) 5344 / 20 49182

E-mail Vertrieb / sales / vente: verkauf@stoll-germany.com

E-Mail allgemein / general / général: info@stoll-germany.com